



Legend Elite Duo

High-Energy Ti:Sapphire Amplifier

Features

- High pulse energy in compact design (>6 mJ, only one pump laser)
- Two stages of TE-cooled amplification
 - Legend Elite regenerative amplifier
 - Single-pass power amplifier
- Integrated Evolution-HE pump laser
- High stability (<0.75% RMS noise)
- High beam quality ($M^2 < 1.5$)
- Pulse width to <40 fs
- 1 kHz or 5 kHz



Mechanical Specifications

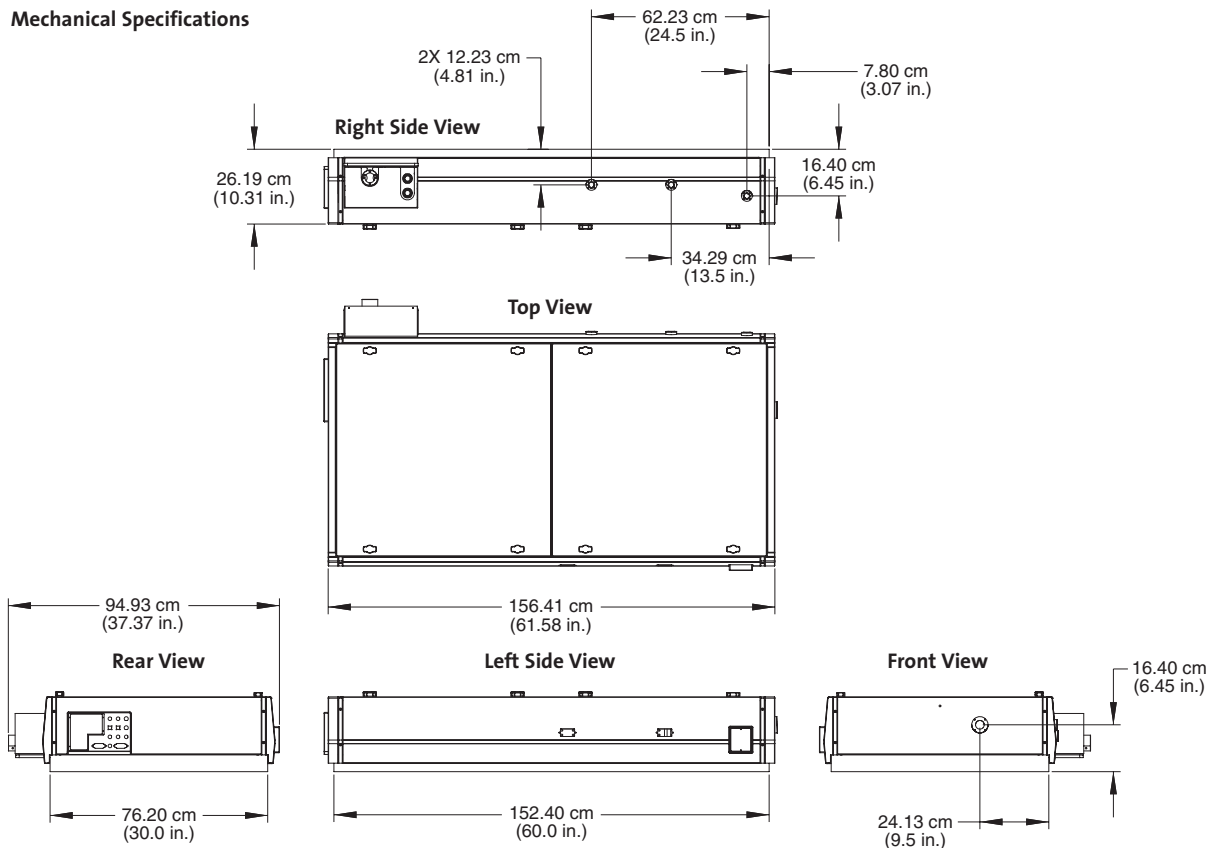

Superior Reliability & Performance

Legend™ Elite Duo

High-Energy Ti:Sapphire Amplifier

System Specifications

	Legend Elite Duo-F	Legend Elite Duo-USP
Center Wavelength (nm)(nominal)		800
Repetition Rate ¹ (kHz)		1 or 5
Pulse Duration ² (fs)(FWHM)	<130	<40
Energy-per-Pulse (mJ)		>6.0 at 1 kHz >1.2 at 5 kHz
Contrast Ratio ³		>1000:1 pre-pulse >100:1 post-pulse
Energy Stability ⁴ (RMS)(8 hours)		<0.75%
Beam Diameter @ 1/e ² (mm)(nominal)		6
Spatial Mode		TEM ₀₀ , M ² <1.5
Polarization		linear, horizontal
Transform Limit ⁵		<1.5 times
Pump Laser		Evolution-HE

¹ Repetition rate must be specified when ordered and will be optimized prior to shipment.

² When seeded by Micra™ (Duo-USP) or Micra, Mira™ or Vitesse™ (Duo-F). For other seed lasers, please contact factory. A Gaussian pulse shape de-convolution factor (0.7) is used to determine the pulse width from an autocorrelator signal measured by a Coherent SSA (Single-Shot Autocorrelator).

³ Contrast ratio is defined as the ratio between the peak intensity of the output pulse to the peak intensity of any other pulse that occurs greater than 1 ns before or after the output pulse.

⁴ Under stable environmental conditions.

⁵ Assuming Gaussian pulse shape.

Typical Pulse Width – 33 fs

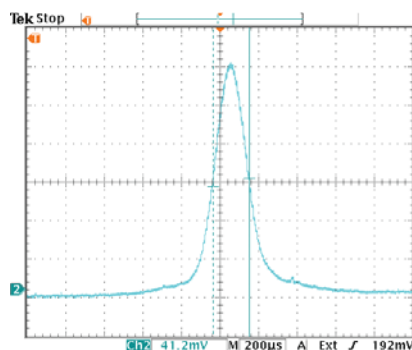

Far-Field Beam Profile

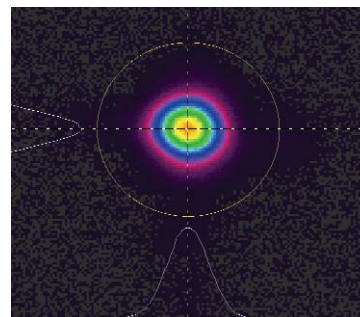

Coherent follows a policy of continuous product improvement. Specifications are subject to change without notice.

Coherent's scientific and industrial lasers are certified to comply with the Federal Regulations (21 CFR Subchapter J) as administered by the Center for Devices and Radiological Health on all systems ordered for shipment after August 2, 1976.

Coherent offers a limited warranty for all Legend Elite Duo amplifiers. For full details of this warranty coverage, please refer to the Service section at www.Coherent.com or contact your local Sales or Service Representative.



www.Coherent.com

Coherent, Inc.
 5100 Patrick Henry Drive
 Santa Clara, CA 95054
 phone (800) 527-3786
 (408) 764-4983
 fax (800) 362-1170
 (408) 988-6838
 e-mail tech.sales@Coherent.com

Benelux +31 (30) 280 6060
 China +86 (10) 6280 0209
 France +33 (0)1 6985 5145
 Germany +49 (6071) 9680
 Italy +39 (02) 34 530 214
 Japan +81 (3) 5635 8700
 Korea +82 (2) 460 7900
 UK +44 (1353) 658 833

